

KAIMAN MAXI





KAIMAN MAXI: combined wall bracket and shelf support for wood shelf 39 to 73mm thick. Can be fixed:

- to cement wall with rawlplug \varnothing 8mm and pan head screw \varnothing 5x50mm.
- to wood panels with \varnothing 5mm countersunk head screw only;
- to wood panels 18mm thick with special designed spreading dowel and M6 bolt.
- to plaster board with umbrella fitting \varnothing 8mm and pan head screw M4x46mm.

Useful fixing method for aligning wall brackets and easy adjustment front to back shelf angle as required.

Capable of supporting a 25Kg load each (shelf weight included), for a shelf 320mm deep.

Zinc alloy

Engineering plastic

Part. no	Finish	Engineering plastic
16105010JL	aluminium PE 11	water green
16105010YD	satin-finished nickel-plated	water green

Other finishes available on request

Box of pcs. 2 with wall hardware included



FIXING TO WALL WITH RAWLPLUG

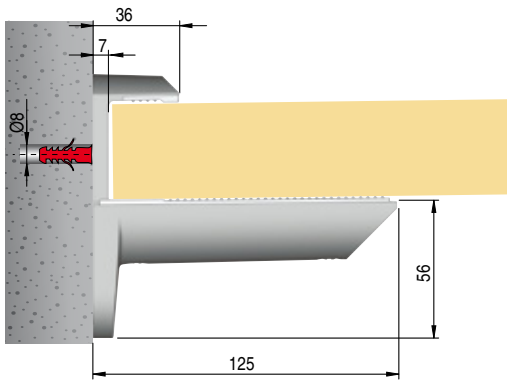

It is the responsibility of the customer:

- to ensure that the wall is of a suitable quality to hold the shelf fixing in place.
- to use the right hardware fitting as required.

SHELF THICKNESS

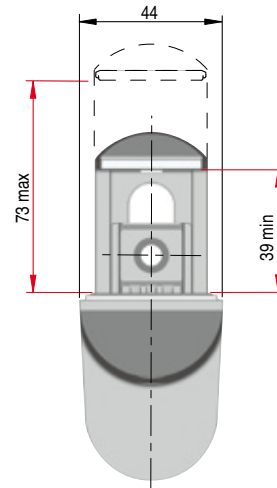

ADJUSTMENTS

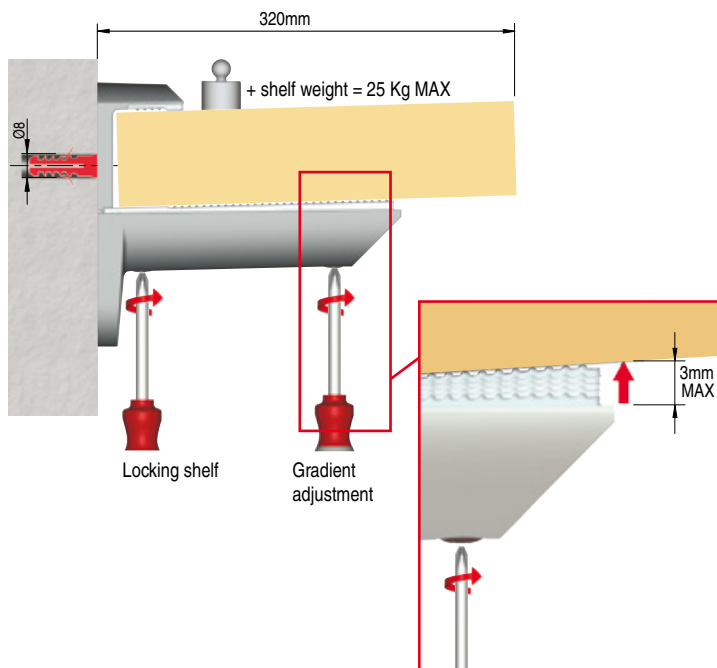

COMBINATION SHELF LOAD AND SHELF DEPTH (The figures refer to 1 shelf support)

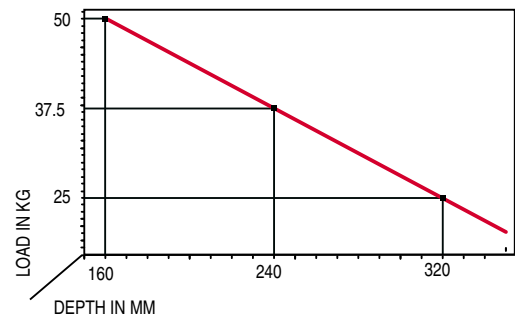

TOP POSITION OF THE RIDGE PLATE

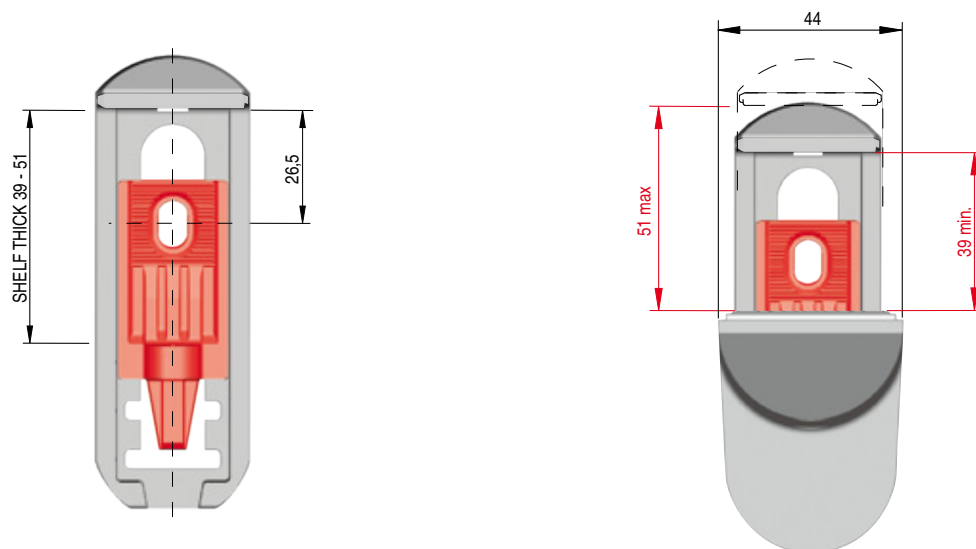

MIDDLE POSITION OF THE RIDGE PLATE

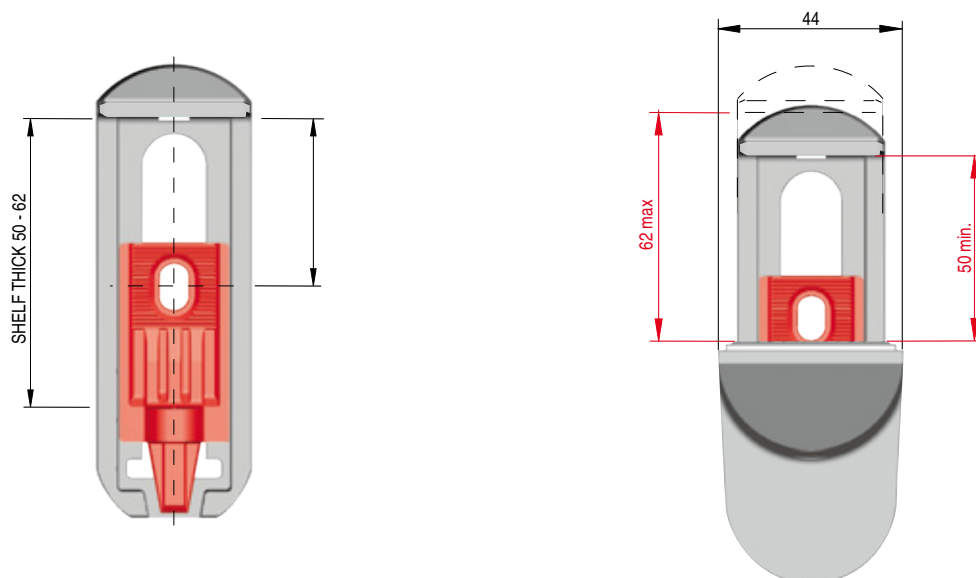

LOWER POSITION OF THE RIDGE PLATE

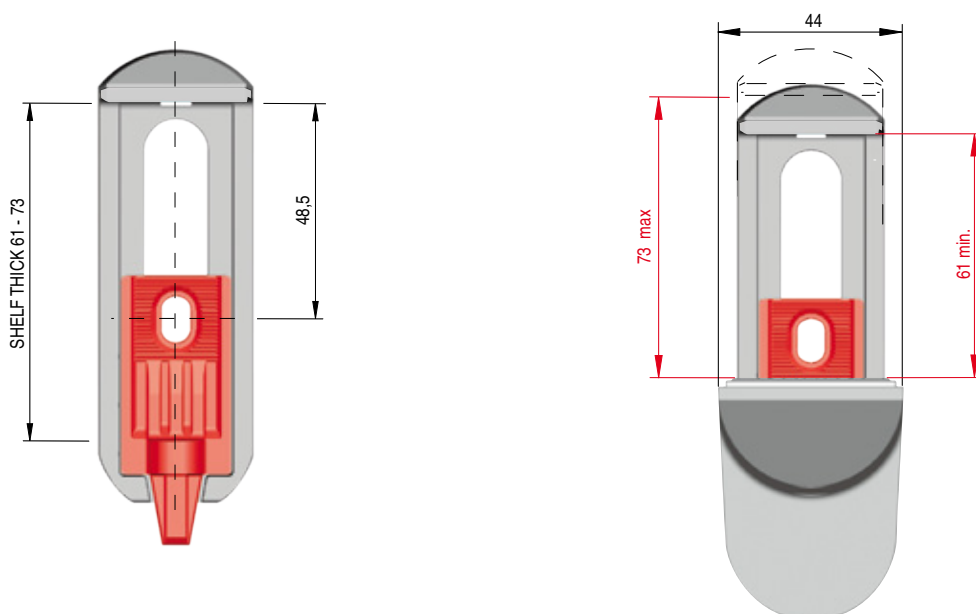



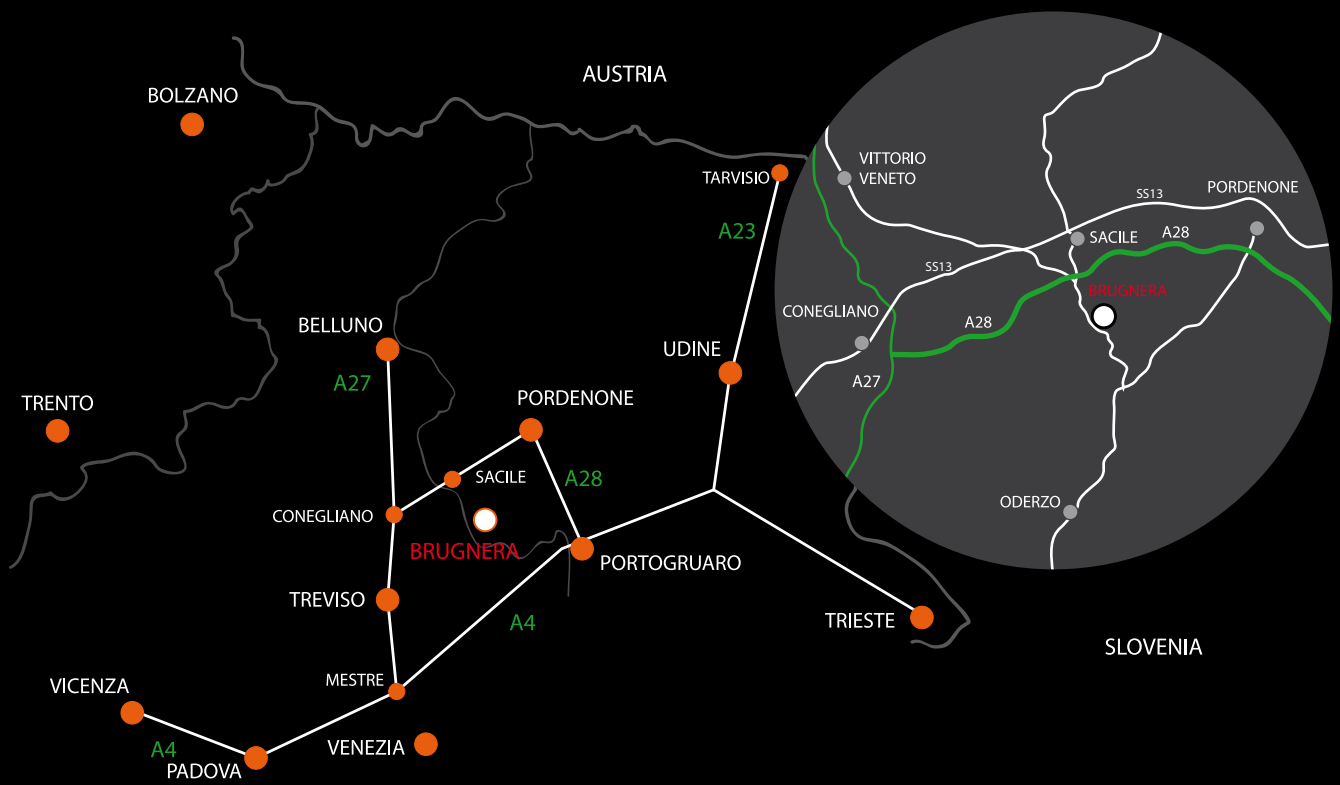

ITALIANA FERRAMENTA

Via Taglio n° 87 I - 33070 Maron di Brugnera (PN) Tel. +39 0434 428211 Fax +39 0434 428242 www.italianaferramenta.com info@italianaferramenta.it